

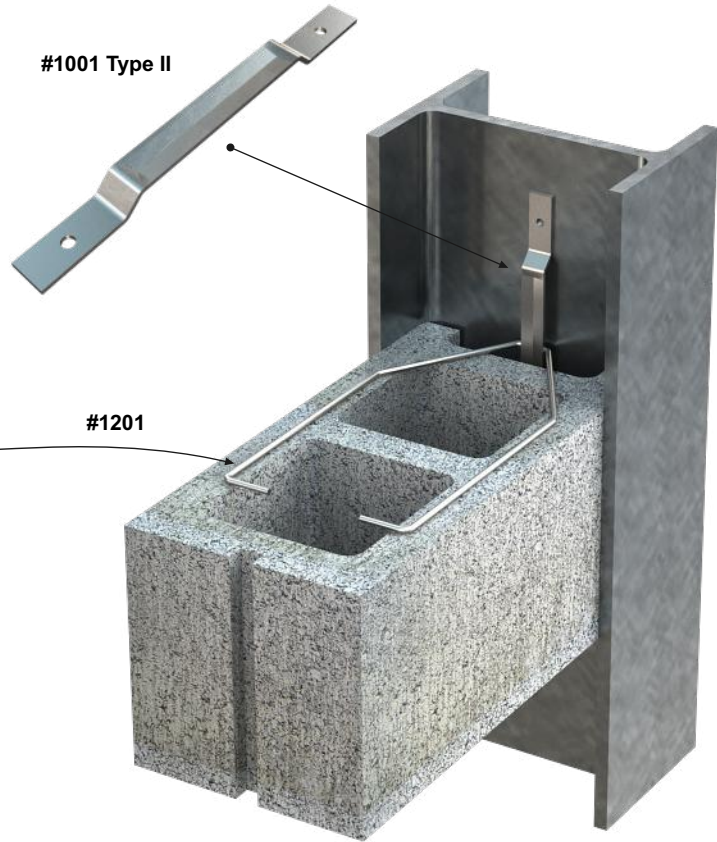

PRODUCT SUBMITTAL

WIRE-BOND

#1201 Beam Tie

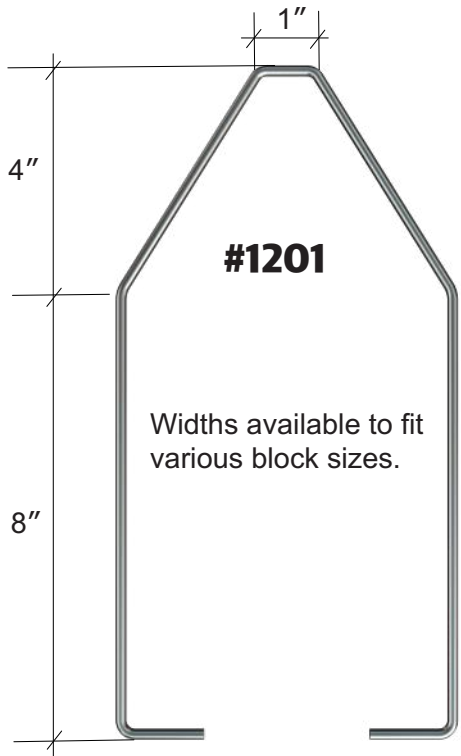

MATERIAL CONFORMANCE	SIZES / FINISHES
<p>ASTM A1064/A1064M - (Cold drawn steel wire) Tensile Strength - 80,000 psi Yield Point - 70,000 psi</p> <p>ACI / ASCE 530 - (Building code requirements for masonry structures)</p> <p>SHEET METAL - (Carbon Steel) ASTM A1008 / A1008M</p> <p>Mill Galvanized / Zinc Coating: ASTM A641 / A641M (0.10 Oz per sq ft)</p> <p>Hot Dip Galvanized after fabrication / Zinc Coating ASTM A153 / A153M-B2 (1.50 oz per sq ft)</p> <p>Stainless Steel ASTM 580 / ASTM 580M Type 304 (Type 316 available on special order)</p> <p>Recycled Content: Mill Galvanized & Hot Dipped, 82.8% Post-Consumer 17% Post Industrial / Pre-Consumer,</p> <p>Stainless Steel, 60% Post Consumer V O C Content - 0%</p> 	<p># 1201 Beam Tie</p> <p>3/16" diameter 1/4" diameter</p> <p>CMU Size:</p> <p>4" 6" 8" 10" 12"</p> <p>#1001 Type II: 12 gauge thick x 3/4" wide</p> <p>5" Length 9" Length</p> <p>Finishes:</p> <p>Mill Galvanized Hot Dip Galvanized Stainless Steel</p>

Corporate Office: 400 Rountree Rd Charlotte, NC 28217
TEL: (800) 849-6722 FAX: (704) 525-

3761
Mailing Address: P.O. Box 240988 Charlotte, NC 28224

WIRE-BOND

www.wirebond.com

Memphis Plant: 2365 Harbor Ave. Memphis, TN 38113
TEL: (800) 441-8359 FAX: (901) 775-9449

Mailing Address: P.O. Box 13124 Memphis, TN 38113