



MasterFormat: 07 13 00

MAY 2024
(Supersedes September 2023)**PRECON®****Pre-Applied/Underslab Waterproofing Membrane****DESCRIPTION**

PRECON is a composite sheet membrane comprised of a non-woven fabric, elastomeric membrane, and W. R. MEADOWS' exclusive, patented PLASMATIC CORE (U.S. Patent No. 7,179,761). The PLASMATIC CORE is a seven-layer matrix designed for toughness and provides the lowest water vapor transmission (WVT) rating on the market. Once concrete is poured against PRECON and the concrete cures, a mechanical bond forms that secures the concrete to the membrane.

USES

PRECON is used as a blindside membrane in vertical applications where access to the positive side is limited. The membrane can also be used for horizontal applications for underslab waterproofing and vaporproofing.

FEATURES/BENEFITS

- Provides a waterproof seal between the membrane and poured concrete wall.
- Helps prevent moisture migration into the structure.
- Reduces methane and radon gas intrusion.

PACKAGING

4' (1.2 m) wide x 50' (15.2 m) long rolls, one roll per carton.

STORAGE AND HANDLING

Store membrane cartons on pallets and cover if left outside. Keep materials away from sparks and flames.

SPECIFICATIONS/STANDARDS

- LARR Report 26023

APPLICATION

Surface Preparation ... Inspect all surfaces for any conditions detrimental to the proper completion of the work. Surfaces should be structurally sound. Remove debris or any other foreign material that could damage the membrane.

PRECON can be used with a caisson wall shoring system without the use of a drainage board, such as MEL-DRAIN™ from W. R. MEADOWS. W. R. MEADOWS recommends proper site drainage, but due to certain site conditions this sometimes cannot be done effectively. The decision to remove the drainage board should be at the discretion of the engineer. In situations where a drainage board is not applied, surface preparation is important. The substrate needs to be sound, solid, and smooth. Any gaps or voids >1" (25 mm) need to be grouted. When PRECON is used with MEL-DRAIN from W. R. MEADOWS, the system can bridge gaps <2" (50.8 mm). However, gaps >2" (50.8 mm) will need to be grouted.

Application Method ... PRECON may be applied at temperatures down to 40° F (5° C); however, in less-than-ideal environments or marginal conditions, consider the use of PRECON LOW TEMP below 60° F (16° C). PRECON LOW TEMP can be used in temperatures down to 25° F (-4° C). MEL-PRIME™ from W. R. MEADOWS should be used to enhance the bond at the selvedge edge when conditions warrant with both PRECON and PRECON LOW TEMP. Prior to application of the blindside membrane, attach MEL-DRAIN™ rolled matrix drainage system from W. R. MEADOWS to lagging or soil retention system.

In vertical applications of PRECON, mechanically attach with fasteners every 12" (304.8 mm) across the top, within ½" (13 mm) of the top edge of the membrane. Install the membrane with the fabric side facing toward the concrete pour.

Remove release paper on 6" (152.4 mm) overlap. Apply membrane and roll press into place with a tile type roller.

If shotcrete is to be applied to the membrane, please reference PRECON SHOTCRETE TECHNICAL BULLETIN available at www.wrmeadows.com.

CONTINUED ON REVERSE SIDE ...**W. R. MEADOWS, INC.**

P.O. Box 338 • HAMPSHIRE, IL 60140-0338
Phone: 847/214-2100 • Fax: 847/683-4544
1-800-342-5976
www.wrmeadows.com • info@wrmeadows.com

HAMPSHIRE, IL / CARTERSVILLE, GA / YORK, PA
FORT WORTH, TX / BENICIA, CA / POMONA, CA
GOODYEAR, AZ / MILTON, ON / SHERWOOD PARK, AB

End Laps ... Overlap membrane 6" (152.4 mm). Prior to overlap, apply BEM, HYDRALASTIC 836, or MEL-ROL® LIQUID MEMBRANE (two-component) from W. R. MEADOWS in area to be lapped. Roll press membrane into BEM, HYDRALASTIC 836, or MEL-ROL LIQUID MEMBRANE. At terminations of membrane, apply BEM, HYDRALASTIC 836, or MEL-ROL LIQUID MEMBRANE 12" (304.8 mm) wide centered over the termination and while still wet, embed 12" (31 cm) wide DETAIL FABRIC into the HYDRALASTIC 836 or MEL-ROL LIQUID MEMBRANE and roll press into place. Ensure that DETAIL FABRIC is centered over the termination with 6" (152.4 mm) on each side of lap edge. Apply additional HYDRALASTIC 836 on all terminations of DETAIL FABRIC.

Additionally, the use of DETAIL TAPE H and DETAIL TAPE V from W. R. MEADOWS can be used in both horizontal and vertical end laps. View PRECON END LAP TAPING METHOD TECHNICAL BULLETIN available at www.wrmeadows.com for full information.

Penetrations and Protrusions ... Detail around all horizontal and vertical penetrations using BEM, HYDRALASTIC 836, or MEL-ROL LIQUID MEMBRANE (two-component) from W. R. MEADOWS. Apply BEM, HYDRALASTIC 836, or MEL-ROL LIQUID MEMBRANE by forming a fillet around the pipe or protrusion, overlapping the fabric side of PRECON and the protrusion a minimum of 2.5" (64 mm). If the gap between the protrusion and the membrane is greater than 1/2" (13 mm), apply DETAIL FABRIC over uncured BEM, HYDRALASTIC 836, or MEL-ROL LIQUID MEMBRANE. All penetration and protrusion surfaces must be clean, rust-free, and sound prior to application of BEM, HYDRALASTIC 836, or MEL-ROL LIQUID MEMBRANE.

*MEL-ROL LIQUID MEMBRANE is a two-component material, not to be confused with MEL-ROL LM.

**PRECON
BLINDSIDE/UNDERSLAB MEMBRANE**

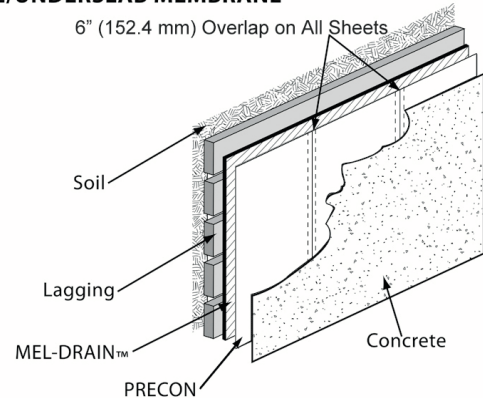

For horizontal applications involving a cluster of penetrations, consider the use of HYDRALASTIC 836. Prior to application of HYDRALASTIC 836, prepare the surfaces of the penetrations as above and provide a block out using 2' x 4' (.6 x 1.2 m) lumber or other in order to create a "pitch pan" area to receive HYDRALASTIC 836.

Patching ... Prior to pouring, inspect membrane for punctures or damage and repair as necessary with HYDRALASTIC 836 and/or DETAIL FABRIC. (BEM or MEL-ROL LIQUID MEMBRANE may be used in place of HYDRALASTIC 836.) In addition, ensure the membrane is free of standing water and has been cleaned of any deleterious materials that will affect the bond of the concrete to the membrane.

Underslab Application ... Refer to ACI 302.1R-04: Chapter 4 – Site Preparation and Placing Environment for sub-grade preparation prior to PRECON placement.

LIMITATIONS/PRECAUTIONS

Concrete should be poured within 60 days of membrane installation. For installations below 40° F (4° C), contact W. R. MEADOWS technical services. When using bar supports, use those with a flat bottom. It is the responsibility of the licensed design professional of record to determine suitability of PRECON as the vapor mitigation barrier based on the published VOC permeance data per project and governmental regulations. It is suggested to follow good industry practices to install a passive (convertible to active) venting system or provide active venting above the mitigation barrier. Install PRECON in clean soil to avoid direct contact with liquid contaminants.

For CAD details, most recent data sheet, sustainability information, and SDS, visit www.wrmeadows.com.

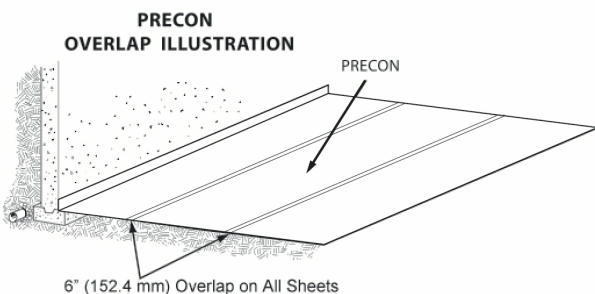

TECHNICAL DATA

Property	Test Method	PRECON Results
Thickness	ASTM D1000	73 mil (1.85 mm)
Low Temp Flexibility	ASTM D1970, 180° @ -20° F (-28.9° C)	Pass
Resistance to Hydrostatic Head	ASTM D5385-93	230' (70 m)
Elongation, Polymeric Membrane	ASTM D412-06	> 400%
Tensile Strength, Film	ASTM D882	9200 psi (63.4 MPa)
Crack Cycling	ASTM C836 @ -15° F (-26° C)	Pass
Puncture Resistance	ASTM E154	> 210 lb. (> 934 N)
Peel Adhesion to Concrete	ASTM D903	10 lb./in (1754 N/m)
Lap Peel Adhesion	ASTM D1876	5.60 PLI
Water Vapor Transmission	ASTM E96B	0.006 perms (0.0024 grains/ft. ² /hr) (0.041 gram/m ² /24 hr)
Resistance to Fungi in Soil	GSA-PBS 07115 – 16 Weeks	No Effect
Radon Transmittance (m/s)	k124/02/95	<3.0 x 10 ⁻⁹
Radon Coefficient (m2/s)	k124/02/95	<5.6 x 10 ⁻¹²
Gas Diffusion Coefficient (m2/s)	ASTM E96, Procedure B Modified (Solvent only – No Water)	>99% Purity Benzene 1.24 x 10 ⁻¹⁴
		>99% Purity Toluene 8.24 x 10 ⁻¹⁵
		>99% Purity Ethylbenzene 1.24 x 10 ⁻¹⁵
		>99% Purity Trichloroethylene 1.90 x 10 ⁻¹⁴
		>99% Purity Tetrachloroethylene (PCE/Perc) 3.21 x 10 ⁻¹⁵
		>99% Purity Xylene 1.53 x 10 ⁻¹⁵
Methane Gas Transmission Rate, (mL/day·m ² ·atm) Cond. 24h @ 74±4°F and 50±10%RH; Gas = Methane (99.99% purity); Test @ 74±4°F:	ASTM D1434	43



LIMITED WARRANTY

W. R. MEADOWS, INC. warrants at the time and place we make shipment, our material will be of good quality and will conform with our published specifications in force on the date of acceptance of the order. Read complete warranty. Copy furnished upon request.

Disclaimer

The information contained herein is included for illustrative purposes only, and to the best of our knowledge, is accurate and reliable. W. R. MEADOWS, INC. cannot however under any circumstances make any guarantee of results or assume any obligation or liability in connection with the use of this information. As W. R. MEADOWS, INC. has no control over the use to which others may put its product, it is recommended that the products be tested to determine if suitable for specific application and/or our information is valid in a particular circumstance. Responsibility remains with the architect or engineer, contractor and owner for the design, application and proper installation of each product. Specifier and user shall determine the suitability of products for specific application and assume all responsibilities in connection therewith.